OPERATION AND MAINTENANCE
INSTRUCTIONS FOR THE

WILCOX[®]

G24[®]

Breakaway Horn Interface Mount

PN: 28300G24

“The Most Trusted Helmet Mount in the World”

Mount Up![®]

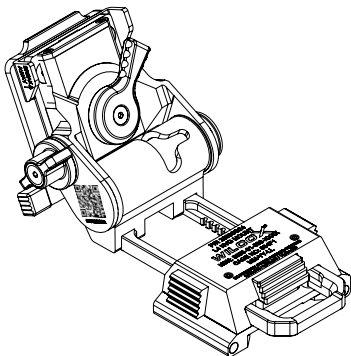

CAGE: 004F1

EAR99 NLR: No Export License Required.

CONFIGURATION

ATTACH/DETACH - ATTACH/DETACH THE G24 MOUNT TO/FROM THE WILCOX FAMILY OF SHROUDS

WILCOX ONE-HOLE SHROUD DEPICTED

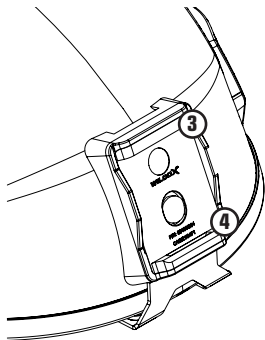

ATTACH MOUNT

Push **(1)** to allow the release mechanism to accept the mount into the shroud.

Position the mount on an angle to insert the interface lip **(2)** into the interface receiver **(3)**.

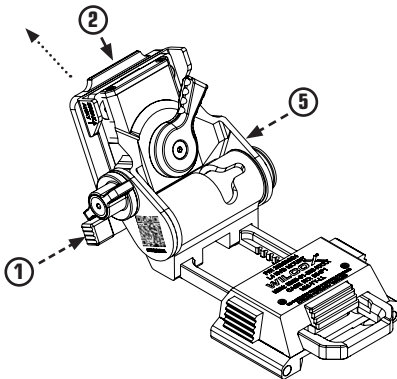

ATTACH/DETACH (CONTINUED)

WILCOX THREE-HOLE SHROUD DEPICTED

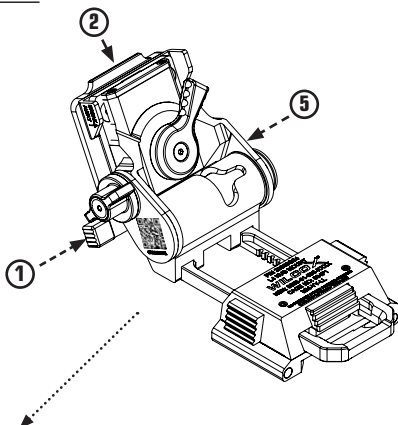
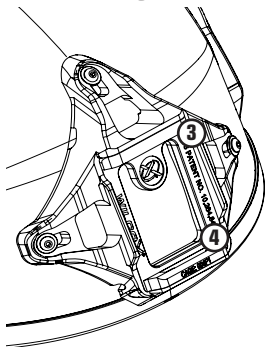

Once the lip is fully engaged in the receiver, pivot the mount into the pocket **(4)**. Once seated, push **(5)** to lock the helmet mount to the shroud.

DETACH MOUNT

Follow the attachment instructions in reverse.

ATTACH/DETACH SHOE - ATTACHMENT OF AN NVG

ATTACH SHOE

Insert the dovetail shoe **(1)** into the receiver **(2)** of the G24 Mount and push in until you hear a click.

Gently pull on the NVG to make sure it is securely mounted.

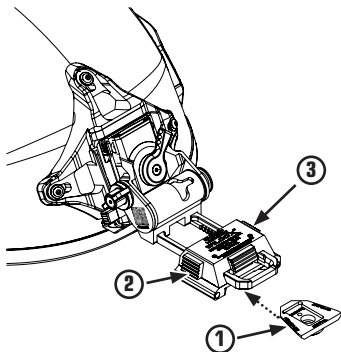

DETACH SHOE

Hold the NVG, push the NVG Release Button **(3)**, then pull the NVG out.

OPERATION

PIVOT - STOWING AND DEPLOYING THE NVG

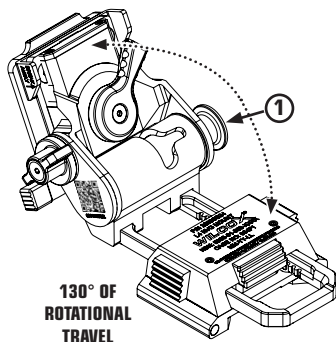

Push the flip release button **(1)** and position the Carriage in the stowed or operational position. Release the button to lock in place.

UP/DOWN - ADJUSTMENT OF THE NVG

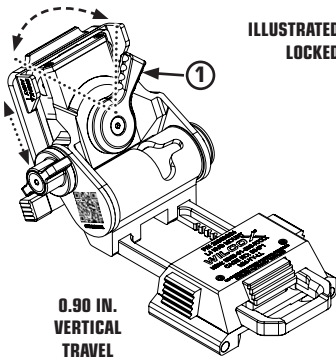

Placing the Lock Lever **(1)** in the unlocked position allows for vertical adjustment up and down. Turn the lever CW to lock.

FORE/AFT - ADJUSTMENT OF THE NVG

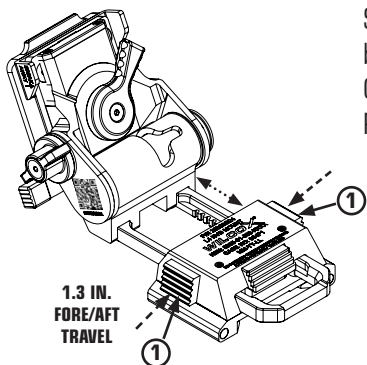

Simultaneously push both buttons **(1)** in to move the Carriage forward or backward. Release the buttons to lock.

TILT - ADJUSTMENT OF THE NVG

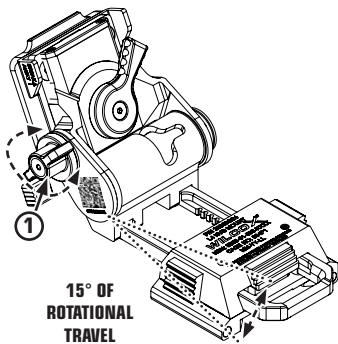

Turn the tilt angle adjustment knob **(1)** CW to raise the angle or CCW to lower the angle.

CARE AND MAINTENANCE

To maintain the reliability of all the adjustments to the mount, keeping the mount clean of any saltwater residue and/or dirt after each use will promote a long-anticipated service life. Flushing the mount with fresh water or by wiping it with a clean damp cloth and lightly lubricating the stainless-steel parts will ensure its intended use. After performing this procedure check all adjustments to assure they are all working properly. If any play develops in the Carriage or Pivot mechanism, the following adjustments can be made to restore its original movement.

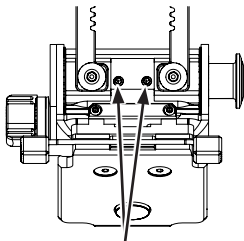

INSERT 1/16 HEX DRIVER TO
ADJUST. TURN CCW TO LOOSEN,
CW TO TIGHTEN.

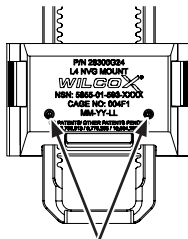

INSERT .050 HEX DRIVER TO
ADJUST. TURN CCW TO LOOSEN,
CW TO TIGHTEN.

Tightening Tilt Adjustment Screws

Tightening NVG Interface Screws

Wilcox prides itself in providing the operator with the most trusted mount in the world. To accomplish this, it is essential to understand the science behind our mounting solution. Without a stable mounting system, an adverse condition can develop that compromises the reason for its existence. Wilcox has engineered the helmet Shroud, Mount, and NVG Shoe to work as one system. Any off-brand shrouds could affect the rigidity, thereby affecting the stability of the goggle. An extensive amount of effort is put into this, and Wilcox cannot honor a warranty claim if an off-brand shroud is used with our mount.

GENERAL SAFETY WARNINGS

▲ WARNING ▲

To prevent potential neck injury when performing operations that could cause entanglement with parachute lines or when fast roping, make sure the breakaway feature is enabled.

BREAKAWAY - ENABLE OR DISABLE THE FEATURE

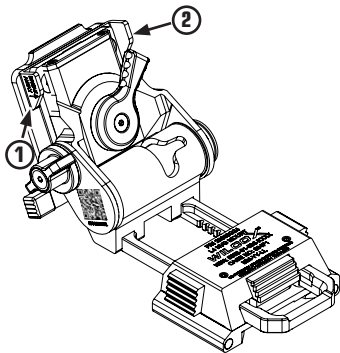

ENABLE

Push in Lever **(1)**.

DISABLE

Push in Lever **(2)**.

WARRANTY CLAIM AND SERVICE INFORMATION

For warranty claim or service work, WX must be contacted in the United States at (603) 431-1331 or Customer Service through our online support page at wilcoxind.com/contact to obtain a **Return Merchandise Authorization (RMA)/Service Call Number (SC)** prior to returning your Wilcox product.

After an RMA/SC number is issued, WX will accept your package at the address indicated below, clearly marked with the RMA/SC number:

Wilcox Industries Corp.
RMA/SC # _____
One Wilcox Way
Newington, NH 03801 USA

The Wilcox product must be securely packaged to prevent damage, accompanied by your name, address, daytime phone number to contact you, and a description of the problem or work you wish to be performed.

Manufactured by:

WILCOX[®]

**Wilcox Industries Corp.
One Wilcox Way
Newington, NH 03801 USA**

Phone: +1 603-431-1331

Fax: +1 603-431-1221



WWW.WILCOXIND.COM

**For troubleshooting service questions,
contact Wilcox between 8am and 5pm EST.**

© 2011-2024 Wilcox Industries Corp. All rights reserved. Printed in USA. US Patents 7,219,370, 8,739,313, 9,709,792, 9,775,395, and 10,264,840. Wilcox[®], the Wilcox "X" logo, "Mount Up![®]", and G24[®] are federally registered trademarks of Wilcox Industries Corp. All other trademarks and registered trademarks in this manual are the property of their respective companies. Specifications and other data are subject to change without notice.